

# SW series

## Digital Scale

- Battery Operated
- Compact Design & Easy Operating
- 1 inch L.C.D Display

TABLE  
ZERO  
NET

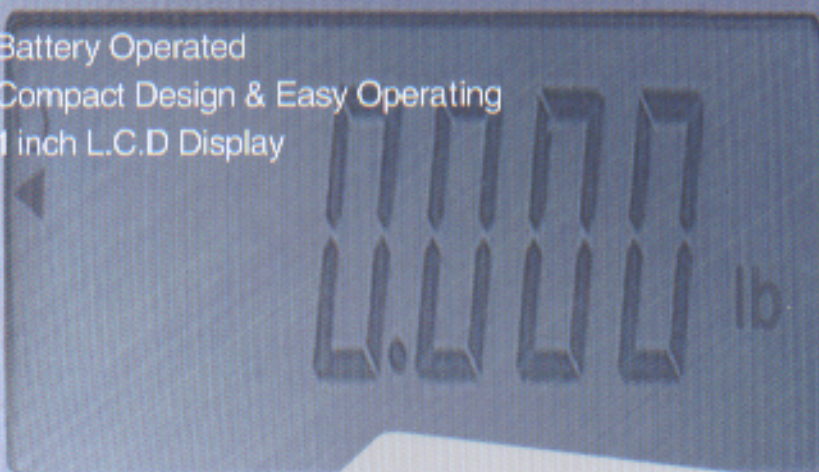

CAPACITY: 5x0.002lb



ISO 9001 certified

**CAS**  
S • C • A • L • E

# SW series Digital Scale

## FEATURES

- Battery Operation with Auto Power Feature
- Large LCD (H=1inch/25mm) Display
- lb/kg/oz Switchable
- Soft Touch Tack Switch
- Compact Design & Stainless Steel platter
- Zero, Net, Stable, Low Battery Indicators
- Function : On/Off, Zero, Tare, Unit
- NTEP Approval number : 99-002

## SPECIFICATIONS

Model	SW - 1				
Capacity	lb	5 × 0.002 lb	10 × 0.005 lb	20 × 0.01 lb	50 × 0.02 lb
	kg	2 × 0.001 kg	5 × 0.002 kg	10 × 0.005 kg	20 × 0.01 kg
	g	2000 × 1 g	5000 × 2 g	10000 × 5 g	20000 × 10 g
	oz	80 × 0.05 oz	160 × 0.1 oz	400 × 0.2 oz	800 × 0.5 oz
Display Digit	5 Digit LCD (1 inch)				
Display Designators	Stable, Zero, Net, Batt.				
Measurement Type	Load Cell				
Power Source	DC 9V (1.5V × 6EA)/ AC Adapter Option				
Power Consumption	0.25W				
Operating Time	Alkaline Dry Battery : 1000hr Mn Battery : 500hr				
Operating Temperature	-10°C ~ +40°C (14°F ~ +104°F)				
Platter Size (mm/inch)	230(W) × 190(D) / 9.05(W) × 7.48(D)				
Dimensions (mm/inch)	260(W) × 287(D) × 137(H) / 10.23(W) × 11.29(D) × 5.39(H)				
Product Weight	3.14kg / 6.92lb				

## OPTION

- Rear Display

## DISPLAY ON THE REAR SIDE

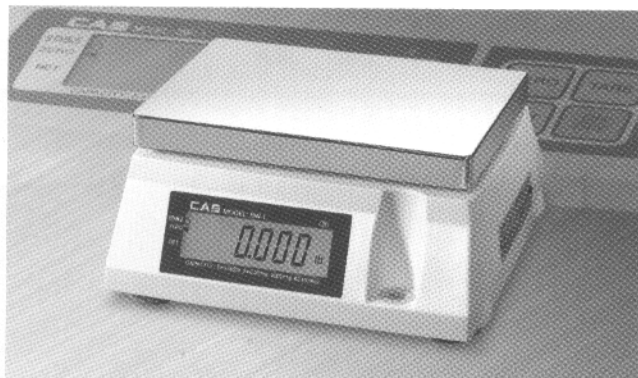

Option

## DIMENSIONS

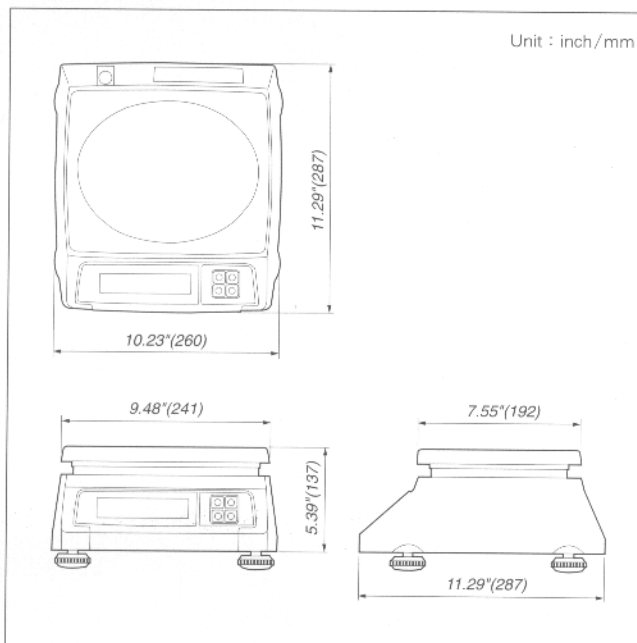

## CAS USA Corporation

NJ OFFICE  
99 Murray Hill Parkway  
East Rutherford, NJ 07073  
(201) 933-9002 Phone  
(201) 933-9025 Fax

CA OFFICE  
1265 N, Manassero st, Suite 310  
Anaheim, CA 92807  
(714) 693-1936 Phone  
(714) 693-9213 Fax

<http://www.cas-usa.com>

Scalemasters, Inc.  
3673 San Gabriel River Pkwy.  
Pico Rivera, Ca. 90660 USA  
(562) 699-0341 phone  
(562) 908-0090 fax