



**PRODUCT SPECIFICATIONS**

## High Capacity Electronic In-Bed Scales

Ideal for:

**Intensive Care • Coronary Care • Geriatric Care  
• Surgical Recovery • Burn Treatment**

Designed for fast, accurate weighing, these electronic in-bed scales feature a flame retardant, antibacterial, self-deodorizing stretcher which is placed under the patient and hydraulically lifted inches from the bed. The touch of a button gives a digital readout of the patient's weight, in pounds or kilograms. The reading doesn't require subtractions to account for bed-weight or bedding. Quickly gather data from an entire floor, without wasted motion or patient discomfort!

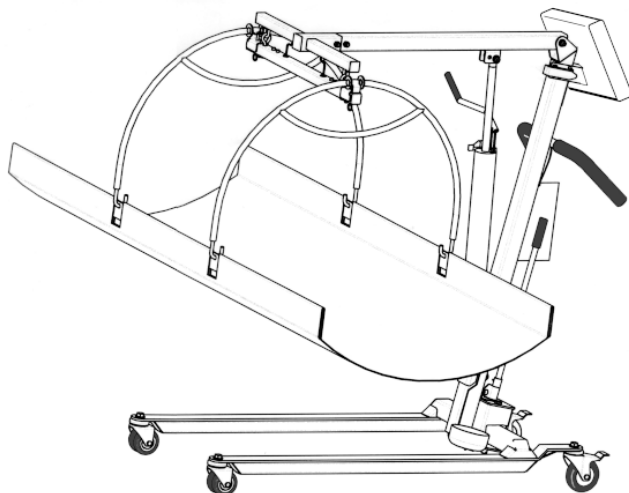

### IB400 Weighmobile

#### -Specifications-

- Capacity - IB400:** 400 lb x 0.1 lb/200kg x 0.5 kg
- Closed Dimensions:** 53"H x 50"L x 25.25"W
- Stretcher:** 6' long, Thermoplastic Staph Check<sup>®</sup> fabric
- Power Supply:** 6 "C" size Alkaline batteries (included) or optional 115 VAC power adapter
- Readout:** 0.7" high-contrast LCD mounted on scale
- Overload Stops:** Prevents damage to weighing sensors

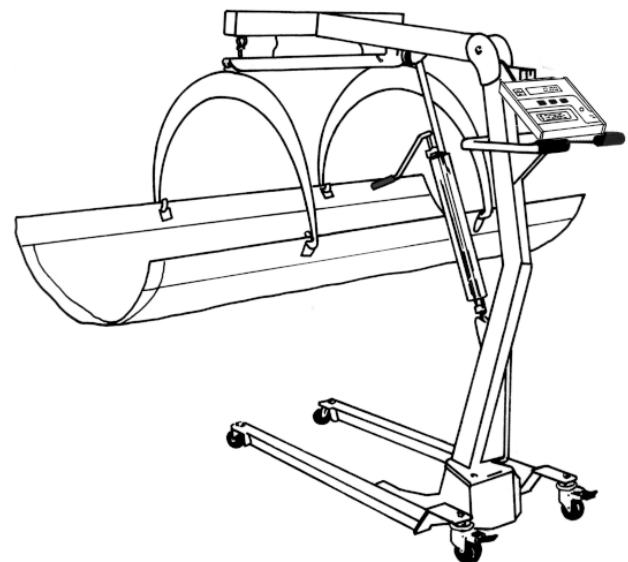

### IB600 Weighmobile

#### -Specifications-

- Capacity:** 600 lb x 0.2 lb/272 kg x 0.1 kg
- Closed Dimensions:** 60"H x 65.9"L x 31.5"W
- Stretcher:** 6' long, Thermoplastic Staph Check<sup>®</sup> fabric
- Power Supply:** 6 "C" size Alkaline batteries (included) or optional 115 VAC power adapter
- Readout:** 0.7" high-contrast LCD mounted on scale
- Overload Stops:** Prevents damage to weighing sensors

#### -Features-

Auto sleep mode, Auto power shut off, Lock/release display, Automatic/manual zero, Motion detector, Adjustable weighing arm (IB400: 25.75" to 72.25" high - IB600: 38.5" to 73" high) and hydraulic lift mechanism.

Cardinal Scale reserves the right to improve, enhance and modify features and specifications without prior notice.